

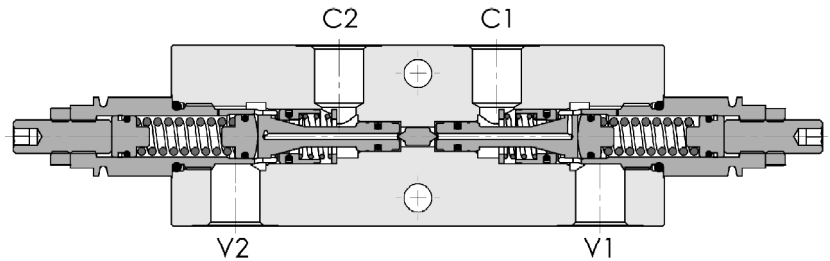

Valvola overcenter doppia, montaggio in linea
Dual overcenter valve, line mounted

Rev.07-2022/07

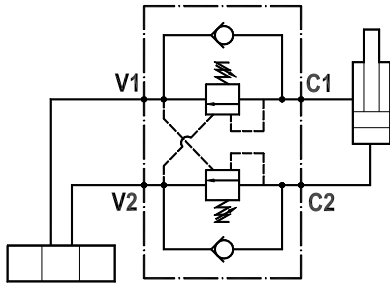

SPECIFICHE TECNICHE

Materiali: corpo in acciaio zincato. I componenti interni sono in acciaio trattato termicamente.

Portata max.: 70 l/min

Taratura max.: 350 bar

Rapporto di pilotaggio: 1 : 4.25 (a richiesta 1 : 2.7, 1 : 8, 1 : 11)

Regolazione pressione: mediante vite

Campo di regolazione pressione: vedere pag. 02

TECHNICAL SPECIFICATIONS

Materials: body is steel made zinc plated. Internal parts are in hardened steel.

Rated flow: up to 70 l/min

Max. setting: 350 bar

Pilot ratio: 1 : 4.25 (1 : 2.7, 1 : 8 and 1 : 11 on request)

Adjustment means: leakproof screw adjustment

Adjustable pressure range: see page 02

DIAGRAMMA PERDITE DI CARICO
PRESSURE DROP CURVES

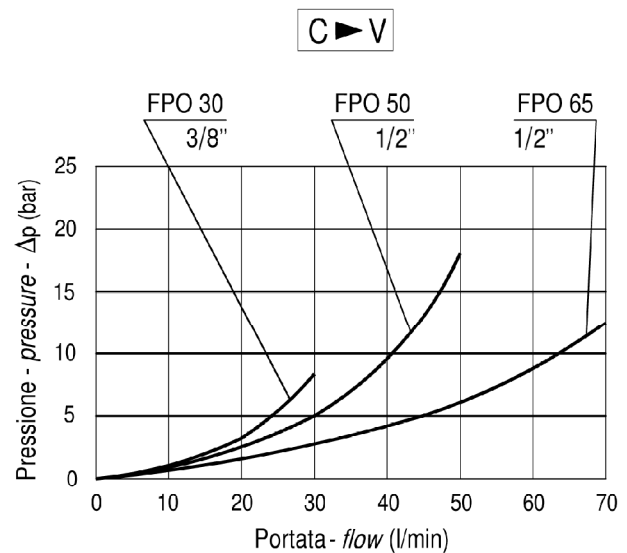
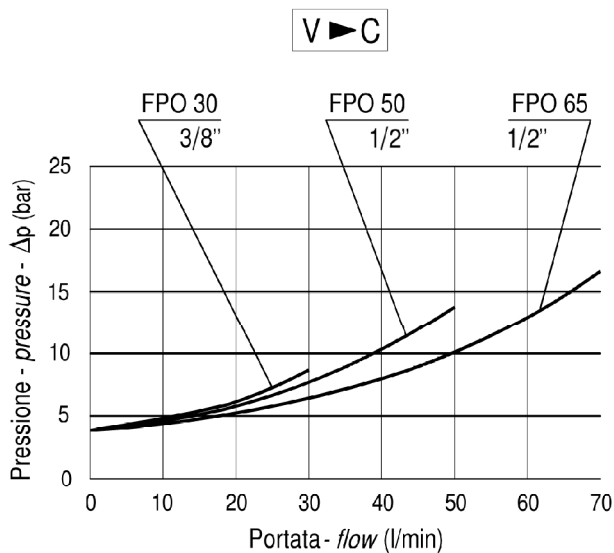



Valvola overcenter doppia, montaggio in linea
Dual overcenter valve, line mounted

Rev.07-2022/07

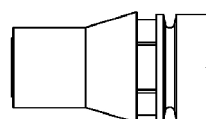
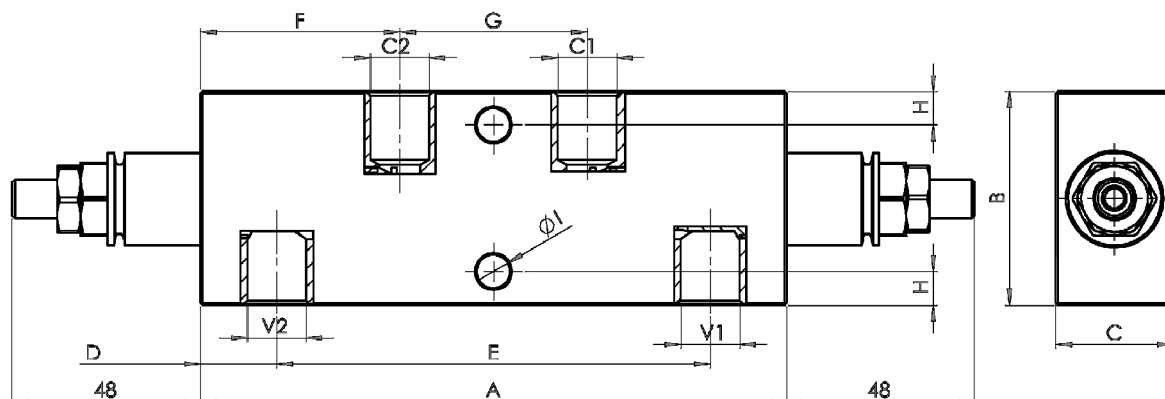

Cappello antimanomissione.
Codice di ordinazione: 9006800010

Tamperproof cap.
Ordering code: 9006800010

MOLLE - SPRINGS				*
Codice Code	Rapp. pil. Pilot ratio	Campo taratura min.-max. bar Adjustable pressure range bar	Increment. press. bar/giro vite Pressure increase bar/turn	Taratura standard bar Standard setting bar
20	1 : 2.7	70 - 230	70	170
	1 : 4.25	60 - 210	42	
	1 : 8	60 - 220	50	
	1 : 11	60 - 250	70	
35	1 : 2.7	120 - 330	80	280
	1 : 4.25	80 - 350	107	
	1 : 8	100 - 350	78	
	1 : 11	80 - 350	109	

TIPO TYPE	V1-C1 V2-C2	A	B	C	D	E	F	G	H	I	PESO WEIGHT
	BSPP	mm	mm	mm	mm	mm	mm	mm	mm	mm	Kg
FPO * D 3/8 L	3/8"	150	55	30	19.5	111	51	48	8.5	8.5	1.850
FPO * D 1/2 L	1/2"	150	65	35	19	112	51	48	11	8.5	2.300

ESEMPIO DI ORDINAZIONE - ORDERING CODE EXAMPLE

F
P
O
*
D
*
L
*
*
*

* "30" / "50" / "65":
 Portata massima - Rated flow

* 3/8 - 3/8" BSPP
 1/2 - 1/2" BSPP (50/65)
 Connessioni - Port sizes

* "20" / "35":
 Campi di taratura pressione - Adjustable pressure range

Guarnizioni - Seals:
 V=Viton *
 Omettere se BUNA-N - Omit if BUNA-N
 B = 1 : 8, C = 1 : 11, D = 1 : 2.7
 Rapporto di pilotaggio - Pilot ratio
 Omettere se standard - Omit if standard *